



Pietro Fiorentini S.p.A.  
via E.Fermi 8/10  
I-36057 Arcugnano (VI)  
Italy

Tel. +39 0444 968.511  
Fax. +39 0444 960.468

[www.fiorentini.com](http://www.fiorentini.com)

via Rosellini 1  
I-20124 Milano  
Italy

Tel. +39 02 696.14.21  
Fax. +39 02 688.04.57

Fiorentini Minireg S.p.A.  
via Faustinella 11  
I-25015 Desenzano del Garda (BS)  
Italy

Tel. +39 030 91.48.511  
Fax. +39 030 91.48.514



## Mod. DIVAL 507-512 - 520-522



REGOLATORI AUTOAZIONATI  
DI BASSA/MEDIA/ALTA  
PRESSIONE A SINGOLO  
STADIO AD OTTURATORE  
BILANCIATO

*SINGLE STAGE  
LOW/MEDIUM/HIGH  
PRESSURE SELF-DRIVEN  
REGULATORS WITH  
BALANCED OBTURATOR*

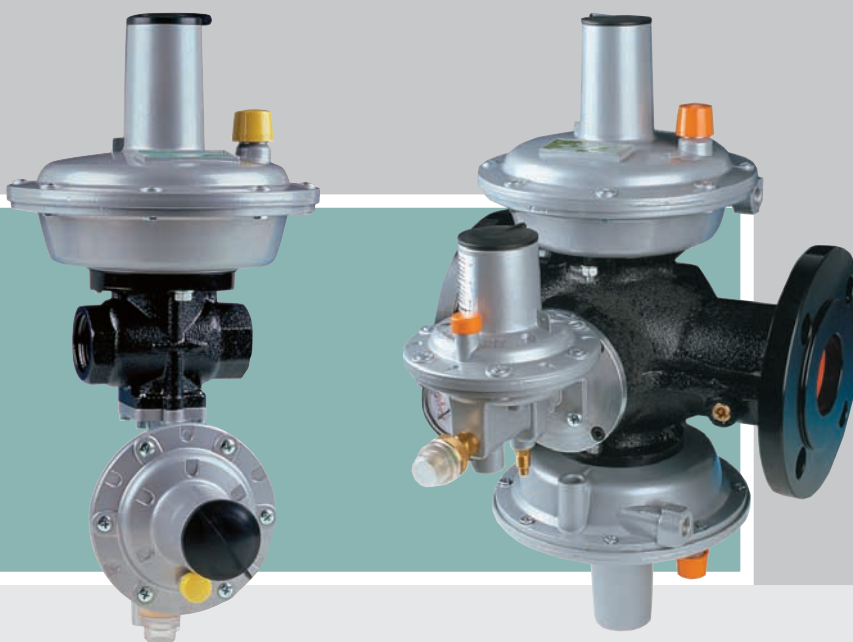





# Mod. DIVAL 507-512 - 520-522



1  
 DIVAL 507 STANDARD CON BLOCCO  
 DIVAL 507 STANDARD WITH SHUT-OFF DEVICE



2  
 DIVAL 512 STANDARD CON BLOCCO  
 DIVAL 512 STANDARD WITH SHUT-OFF DEVICE



3  
 DIVAL 507 STANDARD



4  
 DIVAL 512 STANDARD

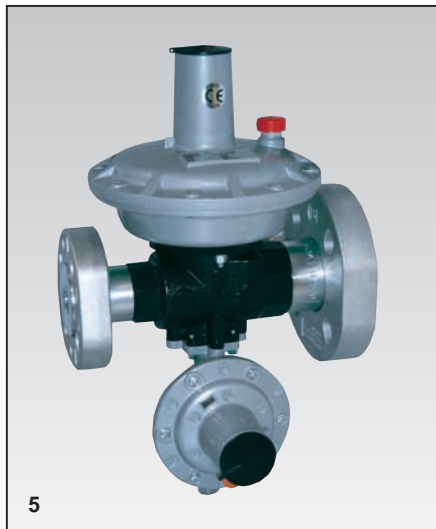

5  
 DIVAL 507 STANDARD CON BLOCCO E FLANGE  
 SCORREVOLI  
 DIVAL 507 STANDARD WITH SHUT-OFF DEVICE  
 AND SLIDING FLANGES



6  
 DIVAL 522 STD CON BLOCCO  
 DIVAL 522 STD WITH SHUT-OFF DEVICE



7  
 DIVAL 522 CON BLOCCO E MANOMETRO IN ENTRATA  
 E USCITA  
 DIVAL 522 WITH SHUT-OFF DEVICE AND INLET -  
 OUTLET MANOMETER



8  
 DIVAL 522 STD SENZA BLOCCO  
 DIVAL 522 STD WITHOUT SHUT-OFF



9  
 DIVAL 520 CON BLOCCO E UN DISPOSITIVO DI  
 REGOLAZIONE  
 DIVAL 520 WITH SHUT-OFF AND ONE DEVICE OF  
 REGULATION





REGOLATORI AUTOAZIONATI DI BASSA/MEDIA/ALTA PRESSIONE A SINGOLO STADIO AD OTTURATORE BILANCIATO  
SINGLE STAGE LOW/MEDIUM/HIGH PRESSURE SELF-DRIVEN REGULATORS WITH BALANCED OBTURATOR

# Mod. DIVAL

**PRESSIONE DI ALIMENTAZIONE**  
INLET PRESSURE

**PRESSIONE DI EROGAZIONE**  
OUTLET PRESSURE

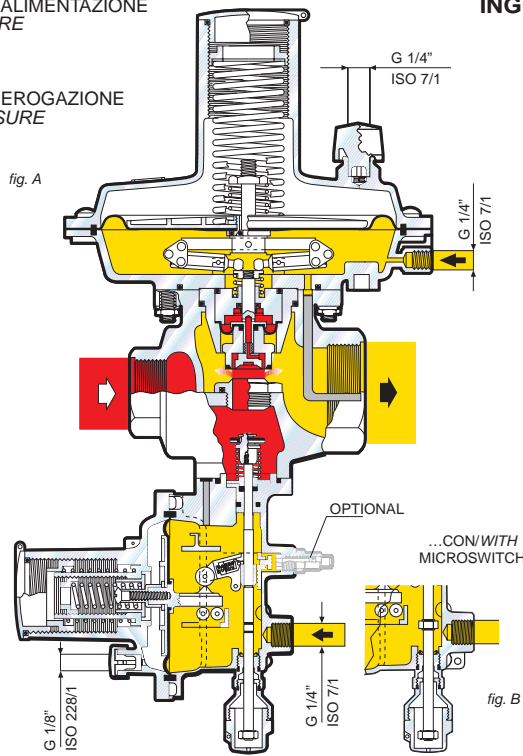

## INGOMBRI - OVERALL DIMENSIONS - DIVAL 507-512

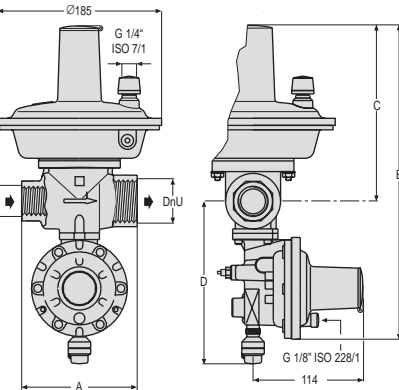

	DIVAL 507	DIVAL 512
A	100±1	130±1
B	347±1	335
C	192±1	193,5
D	183±1	188,5
DnE	1" ISO 7/1	1" ISO 7/1
DnU	1" ISO 7/1	1 1/2" ISO 7/1

tab. 1

## INGOMBRI - OVERALL DIMENSIONS - DIVAL 520-522

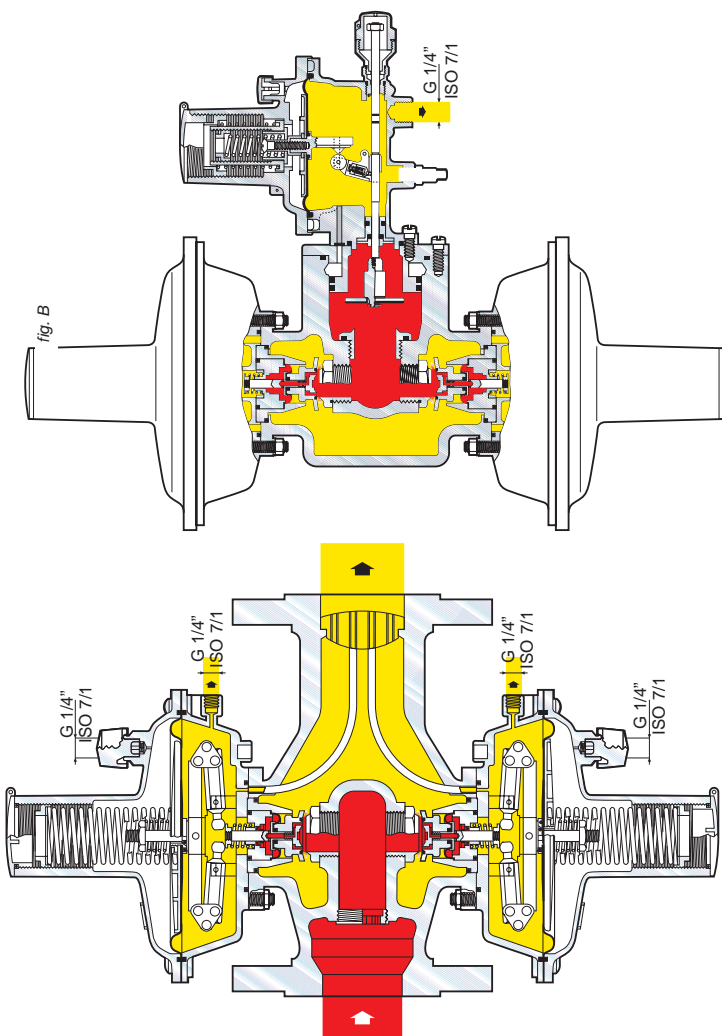

### MATERIALI / MATERIALS

CORPO / BODY  
EN-GJS400-15 UNI EN 1563 (STANDARD / STANDARD)  
ASTM A216WCB (A RICHIESTA / FOR REQUEST)

COPERCHI / COVERS  
G-AISI13 EN AB 44100 - (STANDARD / STANDARD)

### TRATTAMENTI SUPERFICIALI / EXTERNAL TREATMENTS

CORPO / BODY + COPERCHI / COVERS  
SABBIATURA+FOSFATAZIONE+VERNICIATURA POLIURETANICA A POLVERE  
SANDBLASTING+PHOSPHATING+ DUST POLYURETHANE COATING

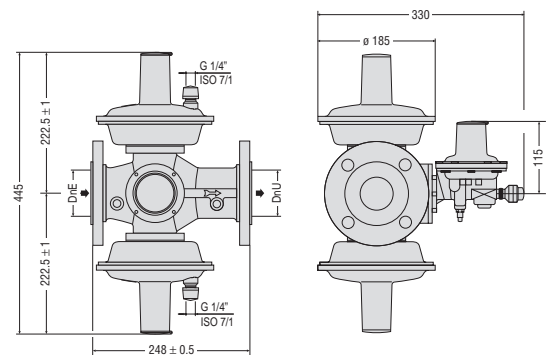
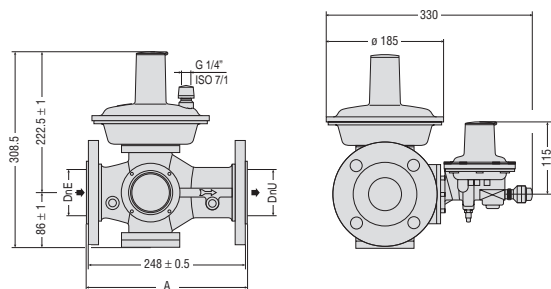

DIVAL 520-522		A
DnE/U	DN 50 PN 40	254 ±1.5
G 2"	ISO 7/1 F	304 ±1.5
2"	NPT F	304 ±1.5

# 507-512 - 520-522



## MOLLE DI REGOLAZIONE - ADJUSTMENT SPRINGS RANGE

<i>Wd</i>	
DIVAL BP	
COD.	CAMPO (mbar) RANGE (mbar)
6447013700	15÷20
6447006800	20÷30
6447013900	30÷40
6447014000	40÷70
6447007100	70÷110

<i>Wd</i>	
DIVAL MP	
COD.	CAMPO (mbar) RANGE (mbar)
6447007100	80÷110
6447014100	110÷180
6447014200	180÷300
DIVAL TR	
6447014300	300÷700
6447014400	700÷1100
6447014500	1100÷2000
6447015100	2000÷3000

## DIFFERENZIALI SFIORO (RISPETTO A Pd) DIFFERENTIAL RELIEF VALVE OPERATING PRESSURE WITH REFERENCE TO THE NOMINAL OUTLET PRESSURE (Pd)

VERSIONE VERSION	COD.	CAMPO (mbar) RANGE (mbar)
BP	6447002400	10÷18
	6447003100	18÷50
MP	6447003800	30÷100
TR	6447003800	50÷259
	6447004500	260÷700
	6447004600	700÷1000

## MOLLE DI REGOLAZIONE ADJUSTMENT SPRINGS RANGE

<i>Wdo</i>			
COD.	CAMPO (mbar) / RANGE (mbar)		
	BP	MP	TR
6447011200	30÷50		
6447011500	50÷180		
6447011500		140÷180	
6447011600		180÷280	
6447005100		280÷450	
6447011600			250÷550
6447015100			550÷850
6447005700			850÷1400
6447005800			1400÷2500
6447005900			2500÷4000
6447006000			4000÷5500

## MOLLE DI REGOLAZIONE ADJUSTMENT SPRINGS RANGE

<i>Wdu</i>			
COD.	CAMPO (mbar) / RANGE (mbar)		
	BP	MP	TR
6447002400	6÷60		
6447002400		10÷60	
6447003800		60÷240	
6447003800			100÷500
6447004500			500÷1000
6447004600			1000÷2000
6447014900			2000÷3500



REGOLATORI AUTOAZIONATI DI BASSA/MEDIA/ALTA PRESSIONE A SINGOLO STADIO AD OTTURATORE BILANCIATO  
SINGLE STAGE LOW/MEDIUM/HIGH PRESSURE SELF-DRIVEN REGULATORS WITH BALANCED OBTURATOR

# Mod. DIVAL

## INTRODUZIONE

I regolatori di pressione della serie DIVAL, sono regolatori del tipo ad azione diretta con otturatore bilanciato, comando a membrana ed azione di contrasto con molla, adatti per basse, medie ed alte pressioni.

I regolatori serie DIVAL sono forniti da fabbrica per il funzionamento con la sola presa d'impulso interna, sia regolatore che valvola di blocco.

Il regolatore e blocco sono predisposti per il collegamento della presa d'impulso esterna (a cura del cliente) in relazione alle tabelle di portata, pagina seguente. Trovano vasto impiego sia nelle installazioni civili che industriali che utilizzano G.N. o G.P.L. o gas non corrosivi.

Grazie alla concezione con otturatore bilanciato si ottiene:

- elevato coefficiente di portata
- elevata precisione di regolazione anche alle massime portate
- zona di pressione di chiusura e pressione di chiusura, relativamente ridotte
- tempi di risposta ridotti
- chiusura ermetica con portata richiesta nulla
- tipo a reazione in apertura (fail to open)
- possibile manutenzione periodica senza smontare il corpo dalle tubazioni
- possibilità di incorporare la valvola di blocco anche su regolatori già installati senza alcuna modifica delle tubazioni.

## CARATTERISTICHE PRINCIPALI

- Campo pressione in entrata bpu:  
BP: 0.5÷10 bar  
MP / TR: 0.5÷20 bar
- Pressione di progetto PS:  
BP: 10 bar  
MP / TR: 20 bar
- Campo di pressione in uscita Wd:  
BP: 15÷110 mbar  
MP: 80÷300 mbar  
TR: 300÷3000mbar
- Campo di pressione valvola di Blocco:  
Wd OPSO BP 30÷180 mbar / MP140÷450 mbar / TR 250÷5500 mbar  
Wd UPSO BP 6÷60 mbar / MP 10÷240 mbar / TR 100÷3500 mbar
- Classe di precisione: AC 5/10/15%
- Classe pressione chiusura: SG Max 25%
- Classe di temperatura: 2 (-20°C +60°C)

## DISPOSITIVI DI SICUREZZA E ACCESSORI

Dispositivo di blocco per aumento di pressione di valle.  
Dispositivo di blocco per diminuzione di pressione di valle.  
Dispositivo di blocco per mancanza di alimentazione.  
Dispositivo di blocco per aumento della temperatura.  
Valvola di sfioro.  
By-pass integrato.  
Il ripristino dei dispositivi di blocco (se installati) è esclusivamente manuale.

CONFORME ALLE DIRETTIVE 97/23 CE PED

## INTRODUCTION

The DIVAL series of spring loaded, diaphragm controlled balanced plug regulators are suitable for low, medium and high pressure.

Divals and shut-off device series regulators are supplied with internal sensing lines. Both the regulator and the shut-off device are preset for optional connection to an external sensing line by the customer.

They are widely used in both civil and industrial installations using Natural Gas, LPG and other non corrosive gases.

The special regulator design combined with a balanced plug result in:

- high flow rate coefficient,
- high accuracy, even at maximum flow rates,
- reduced lock up pressure zone and lock up pressure,
- reduced response times,
- no internal leakage at zero flow rate,
- fail to open type,
- periodical maintenance without disassembling the body from the pipework,
- ability to retrofit the slam-shut (OPSO/UPSO), without modifying the existing piping.

## MAIN FEATURES

- Inlet pressure range bpu:  
BP: 0.5÷10 bar - bpu: 7.2÷145 Psi  
MP / TR: 0.5÷20 bar - bpu: 7.2÷290 Psi
- Max allowable pressure PS:  
BP: 10 bar - PS 145 Psi  
MP / TR: 20 bar - PS 290 Psi
- Outlet pressure range Wd:  
BP: 15÷110 mbar - BP: 0.21÷44.2" wc  
MP: 80÷300 mbar - MP: 32÷120.5" wc  
TR: 300÷3000 mbar - TR: 120.5÷1205.5" wc
- Shut - off device setting range:  
Wd OPSO BP 30÷180 mbar - Wd OPSO: 12÷72.3" wc  
Wd OPSO MP 40÷450 mbar - Wd OPSO: 56.2÷180.8" wc  
Wd OPSO TR 250÷5500 mbar - Wd OPSO: 100.4÷2210" wc  
Wd UPSO BP 6÷60 mbar - Wd UPSO: 2.4÷24.1" wc  
Wd UPSO MP 10÷240 mbar - Wd UPSO: 4.0÷96.4" wc  
Wd UPSO TR 100÷3500 mbar - Wd UPSO: 40.1÷1406.5" wc
- Accuracy class: AC 5/10/15%
- Lock up pressure class: SG 25% Max
- Temperature class: 2 (-20°C +60°C) - (-68°F +140°F)

## SAFETY DEVICES AND ACCESSORIES

Over pressure shut-off device (OPSO).  
Under pressure shut-off device (UPSO).  
Safety shut-off device for lack of feeding.  
Thermic valve.  
Relief valve.  
Integrated by-pass.  
The reset of the safety shut-off devices (whenever present) is solely manual.

CONFORMING TO THE 97/23 CE PED DIRECTIVE



# 507-512 - 520-522

## DIVAL 507 PRESA DI IMPULSO INTERNA CON PREDISPOSIZIONE ESTERNA DIVAL 507 WITH INTERNAL WITH PRESETTING EXTERNAL SENSINE LINE

Pd:15-100mbar BP Flow rate stmc/h G.N.				Pd : 100-300mbar MP Flow rate stmc/h G.N.				Pd : 300-3000mbar TR Flow rate stmc/h G.N.			
Pu bar	AC5	AC10	AC20	Pu bar	AC5	AC10	AC20	Pu bar	AC5	AC10	AC20
Pd +0,5bar	80	90	90	Pd +0,5bar	95	105	120	Pd +0,5bar	100	140	150
Pd +1,0bar	85	110	125	Pd +1,0bar	140	160	80	Pd +1,5bar	150	200	220
Pd +2,5bar	80	110	140	Pd +2,5bar	180	200	220	Pd +3,0bar	200	250	250
Pd +5,0bar	80	110	150	Pd +5,0bar	180	200	220	Pd +5,0bar	250	250	250

## DIVAL 512 PRESA DI IMPULSO INTERNA CON PREDISPOSIZIONE ESTERNA DIVAL 512 WITH INTERNAL WITH PRESETTING EXTERNAL SENSINE LINE

Pd:15-100mbar BP Flow rate stmc/h G.N.				Pd : 100-300mbar MP Flow rate stmc/h G.N.				Pd : 300-3000mbar TR Flow rate stmc/h G.N.			
Pu bar	AC5	AC10	AC20	Pu bar	AC5	AC10	AC20	Pu bar	AC5	AC10	AC20
Pd +0,5bar	90	110	115	Pd +0,5bar	100	115	130	Pd +0,5bar	105	140	200
Pd +1,0bar	150	160	165	Pd +1,0bar	170	200	220	Pd +1,5bar	160	200	280
Pd +2,5bar	120	165	170	Pd +2,5bar	280	320	340	Pd +3,0bar	190	280	360
Pd +5,0bar	140	165	170	Pd +5,0bar	300	350	370	Pd +5,0bar	280	360	400

## DIVAL 520 PRESA DI IMPULSO INTERNA CON PREDISPOSIZIONE ESTERNA DIVAL 520 WITH INTERNAL WITH PRESETTING EXTERNAL SENSINE LINE

Pd:15-100mbar BP Flow rate stmc/h G.N.				Pd : 100-300mbar MP Flow rate stmc/h G.N.				Pd : 300-3000mbar TR Flow rate stmc/h G.N.			
Pu bar	AC5	AC10	AC20	Pu bar	AC5	AC10	AC20	Pu bar	AC5	AC10	AC20
Pd +0.5bar	85	95	95	Pd +0.5bar	100	110	125	Pd +0.5bar	105	150	160
Pd +1.0bar	90	115	130	Pd +1.0bar	200	200	225	Pd +1.0bar	158	210	235
Pd +2.5bar	85	115	145	Pd +2.5bar	187	210	235	Pd +2.5bar	210	265	270
Pd +5.0bar	85	115	155	Pd +5.0bar	187	210	235	Pd +5.0bar	265	265	270

## DIVAL 522 PRESA DI IMPULSO INTERNA CON PREDISPOSIZIONE ESTERNA DIVAL 522 WITH INTERNAL WITH PRESETTING EXTERNAL SENSINE LINE

Pd:15-100mbar BP Flow rate stmc/h G.N.				Pd : 100-300mbar MP Flow rate stmc/h G.N.				Pd : 300-3000mbar TR Flow rate stmc/h G.N.			
Pu bar	AC5	AC10	AC20	Pu bar	AC5	AC10	AC20	Pu bar	AC5	AC10	AC20
Pd +0.5bar	150	200	200	Pd +0.5bar	150	170	170	Pd +0.5bar	200	260	295
Pd +1.0bar	230	250	280	Pd +1.0bar	240	320	340	Pd +1.0bar	350	460	500
Pd +2.5bar	230	250	300	Pd +2.5bar	460	580	610	Pd +2.5bar	800	900	1000
Pd +5.0bar	200	270	300	Pd +5.0bar	400	450	470	Pd +5.0bar	900	1000	1000

Portata in GPL: moltiplicare il valore in tabella x 1.2  
Portata in Azoto: moltiplicare il valore in tabella x 0.789

LEGENDA:  
Pd: Pressione in uscita - Pu: Pressione in ingresso - Ac: Grado di precisione

## DIVAL 507 PRESA DI IMPULSO INTERNA E ESTERNA ATTIVE\* DIVAL 507 WITH INTERNAL AND EXTERNAL SENSINE LINE ACTIVE\*

Pd:15-100mbar BP Flow rate stmc/h G.N.				Pd : 100-300mbar MP Flow rate stmc/h G.N.				Pd : 300-3000mbar TR Flow rate stmc/h G.N.			
Pu bar	AC5	AC10	AC20	Pu bar	AC5	AC10	AC20	Pu bar	AC5	AC10	AC20
Pd +0,5bar	80	90	90	Pd +0,5bar	95	105	120	Pd +0,5bar	100	250	250
Pd +1,0bar	130	135	140	Pd +1,0bar	140	160	180	Pd +1,5bar	190	250	250
Pd +2,5bar	210	230	250	Pd +2,5bar	230	250	250	Pd +3,0bar	220	250	250
Pd +5,0bar	220	250	300	Pd +5,0bar	250	250	250	Pd +5,0bar	250	250	250

\* Collegamento della presa d'impulso esterna a cura del cliente  
Connection to the external sensine line by the client

## DIVAL 512 PRESA DI IMPULSO INTERNA E ESTERNA ATTIVE\* DIVAL 512 WITH INTERNAL AND EXTERNAL SENSINE LINE ACTIVE\*

Pd:15-100mbar BP Flow rate stmc/h G.N.				Pd : 100-300mbar MP Flow rate stmc/h G.N.				Pd : 300-3000mbar TR Flow rate stmc/h G.N.			
Pu bar	AC5	AC10	AC20	Pu bar	AC5	AC10	AC20	Pu bar	AC5	AC10	AC20
Pd +0,5bar	90	110	115	Pd +0,5bar	100	115	130	Pd +0,5bar	100	140	200
Pd +1,0bar	150	170	175	Pd +1,0bar	170	200	220	Pd +1,5bar	180	250	310
Pd +2,5bar	200	280	290	Pd +2,5bar	400	400	400	Pd +3,0bar	250	330	400
Pd +5,0bar	230	300	325	Pd +5,0bar	400	400	400	Pd +5,0bar	400	400	400

\* Collegamento della presa d'impulso esterna a cura del cliente  
Connection to the external sensine line by the client

## DIVAL 520 PRESA DI IMPULSO INTERNA E ESTERNA ATTIVE\* DIVAL 520 WITH INTERNAL AND EXTERNAL SENSINE LINE ACTIVE\*

Pd:15-100mbar BP Flow rate stmc/h G.N.				Pd : 100-300mbar MP Flow rate stmc/h G.N.				Pd : 300-3000mbar TR Flow rate stmc/h G.N.			
Pu bar	AC5	AC10	AC20	Pu bar	AC5	AC10	AC20	Pu bar	AC5	AC10	AC20
Pd +0.5bar	85	90	95	Pd +0.5bar	100	110	125	Pd +0.5bar	105	270	270
Pd +1.0bar	140	150	155	Pd +1.0bar	200	200	225	Pd +1.0bar	205	270	270
Pd +2.5bar	225	245	260	Pd +2.5bar	240	240	260	Pd +2.5bar	230	270	270
Pd +5.0bar	235	270	380	Pd +5.0bar	265	265	270	Pd +5.0bar	265	270	270

\* Collegamento della presa d'impulso esterna a cura del cliente  
Connection to the external sensine line by the client

## DIVAL 522 PRESA DI IMPULSO INTERNA E ESTERNA ATTIVE\* DIVAL 522 WITH INTERNAL AND EXTERNAL SENSINE LINE ACTIVE\*

Pd:15-100mbar BP Flow rate stmc/h G.N.				Pd : 100-300mbar MP Flow rate stmc/h G.N.				Pd : 300-3000mbar TR Flow rate stmc/h G.N.			
Pu bar	AC5	AC10	AC20	Pu bar	AC5	AC10	AC20	Pu bar	AC5	AC10	AC20
Pd +0.5bar	150	200	200	Pd +0.5bar	150	180	210	Pd +0.5bar	200	260	295
Pd +1.0bar	230	250	280	Pd +1.0bar	250	280	325	Pd +1.0bar	350	460	500
Pd +2.5bar	380	400	450	Pd +2.5bar	510	550	600	Pd +2.5bar	800	900	1000
Pd +5.0bar	400	450	500	Pd +5.0bar	600	650	700	Pd +5.0bar	900	1000	1000

\* Collegamento della presa d'impulso esterna a cura del cliente  
Connection to the external sensine line by the client

LPG flow rate: multiply the value in the table x 1.2  
Azote flow rate: multiply the value in the table x 0.789

LEGEND:  
Pd: Outlet pressure - Pu: Inlet pressure - Ac: Accuracy





REGOLATORI AUTOAZIONATI DI BASSA/MEDIA/ALTA PRESSIONE A SINGOLO STADIO AD OTTURATORE BILANCIATO  
 SINGLE STAGE LOW/MEDIUM/HIGH PRESSURE SELF-DRIVEN REGULATORS WITH BALANCED OBTURATOR

# Mod. DIVAL 507

## ENTRATA - INLET

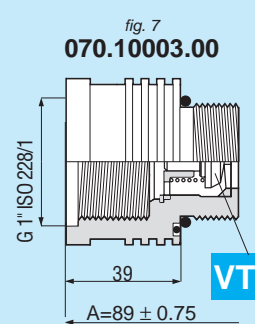
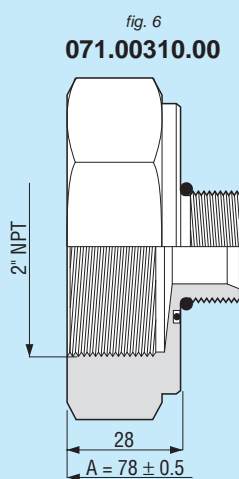
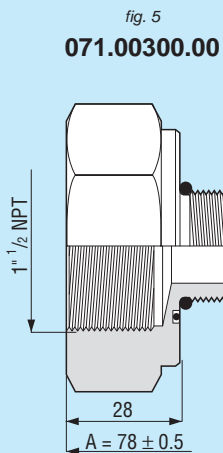
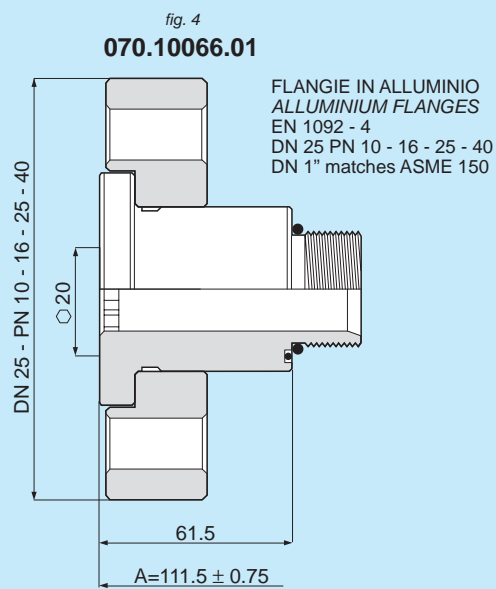
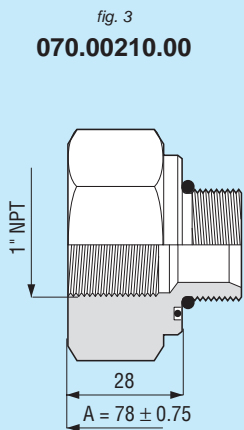
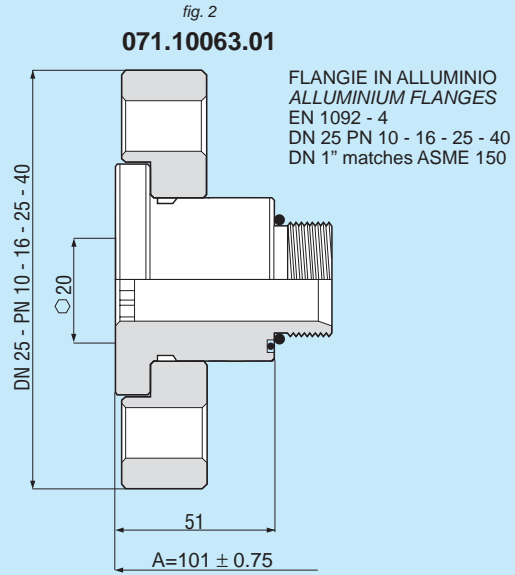
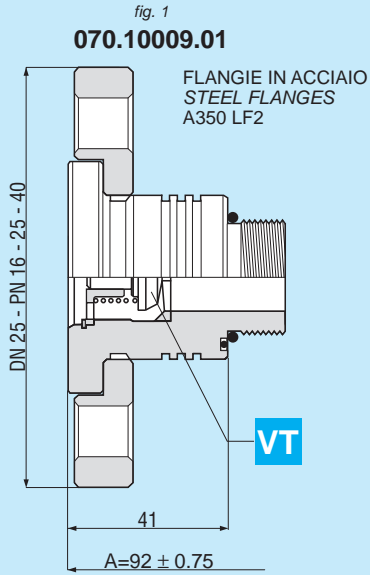

**VT** = con Valvola Termica  
 with Thermic Valve



# RACCORDERIA - FITTINGS

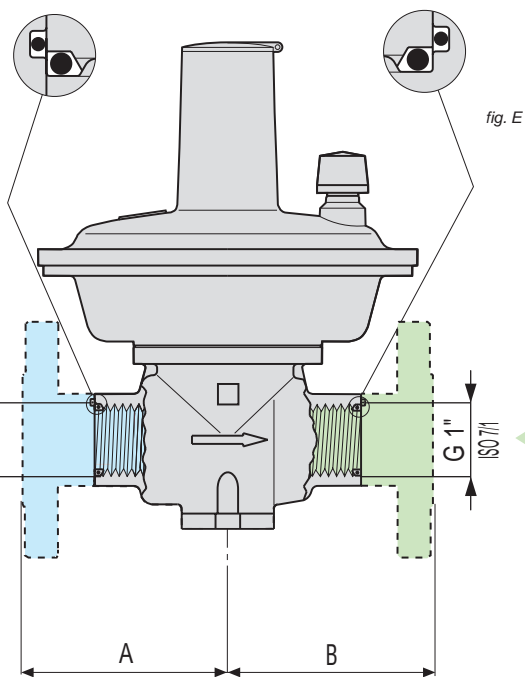

## USCITA - OUTLET

fig. 1  
**071.10063.01**

FLANGIE IN ALLUMINIO  
ALLUMINIUM FLANGES  
EN 1092 - 4  
DN 25 PN 10 - 16 - 25 - 40  
DN 1" matches ASME 150

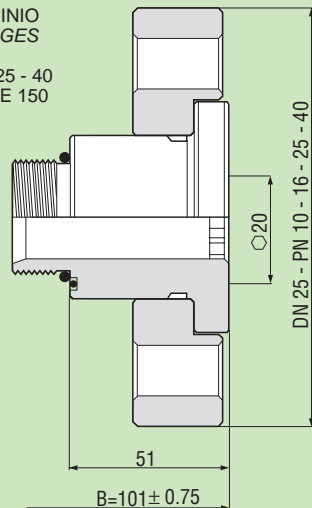

### ESEMPI DI INSTALLAZIONE APPLICATION AVAILABLE

fig. F

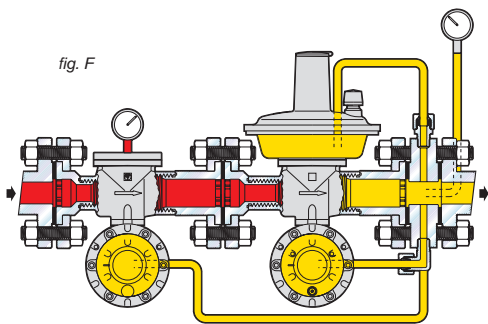

fig. G

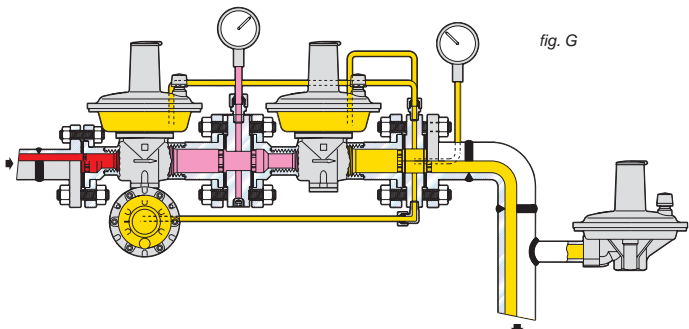

fig. 2  
**070.00210.00**

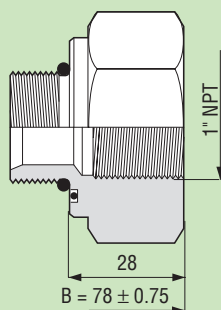

fig. 3  
**071.00300.00**

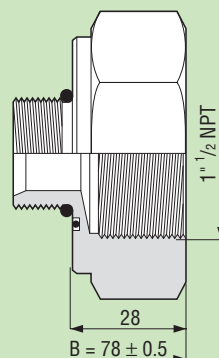

fig. 4  
**071.00310.00**

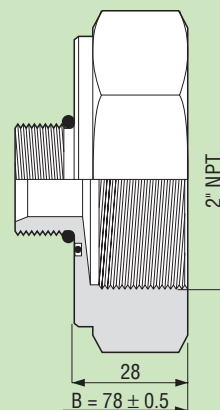
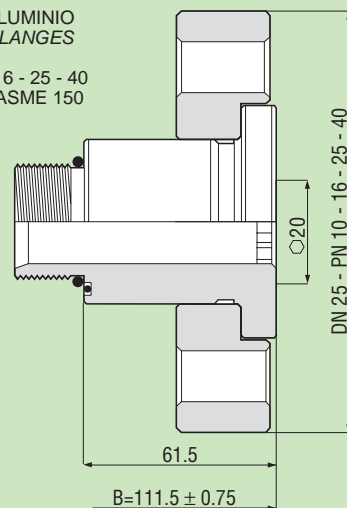

fig. 5  
**070.10066.01**

FLANGIE IN ALLUMINIO  
ALLUMINIUM FLANGES  
EN 1092 - 4  
DN 25 PN 10 - 16 - 25 - 40  
DN 1" matches ASME 150





REGOLATORI AUTOAZIONATI DI BASSA/MEDIA/ALTA PRESSIONE A SINGOLO STADIO AD OTTURATORE BILANCIATO  
 SINGLE STAGE LOW/MEDIUM/HIGH PRESSURE SELF-DRIVEN REGULATORS WITH BALANCED OBTURATOR

# Mod. DIVAL 512

## ENTRATA - INLET

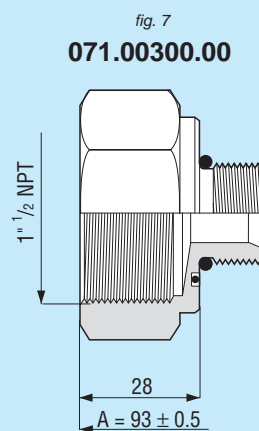
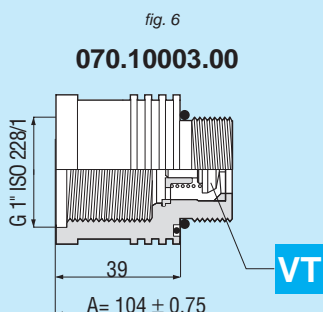
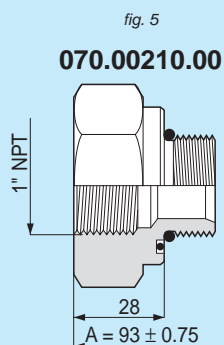
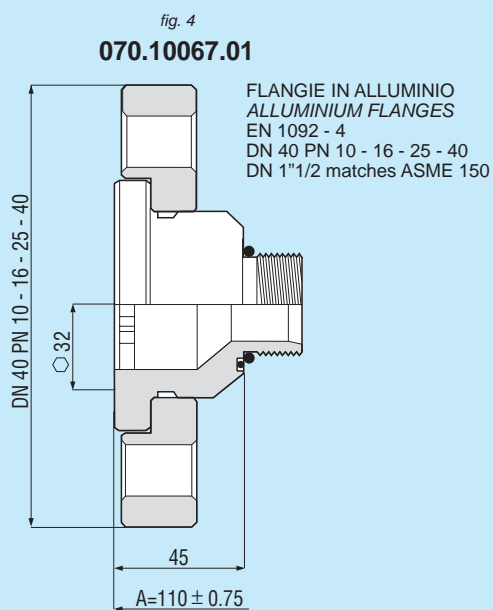
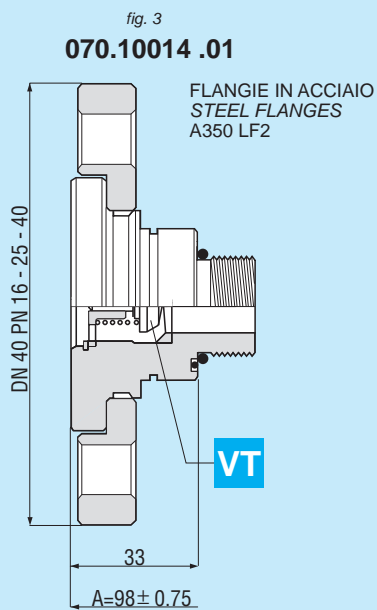
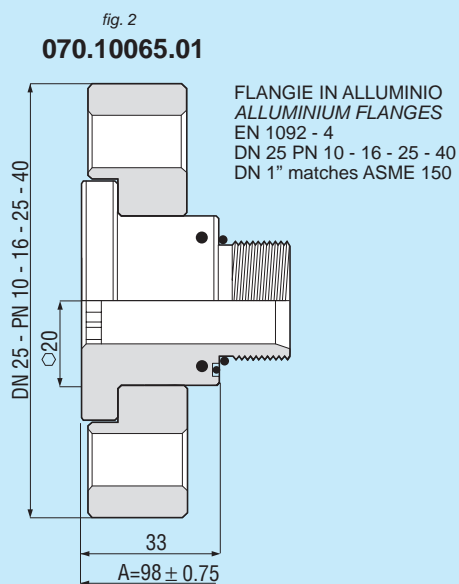
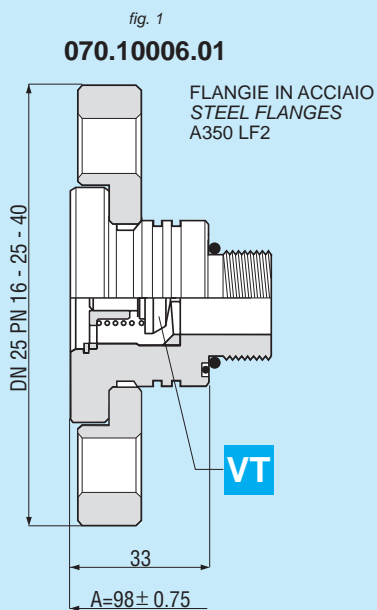

**VT** = con Valvola Termica / with Thermic Valve

# RACCORDERIA - FITTINGS

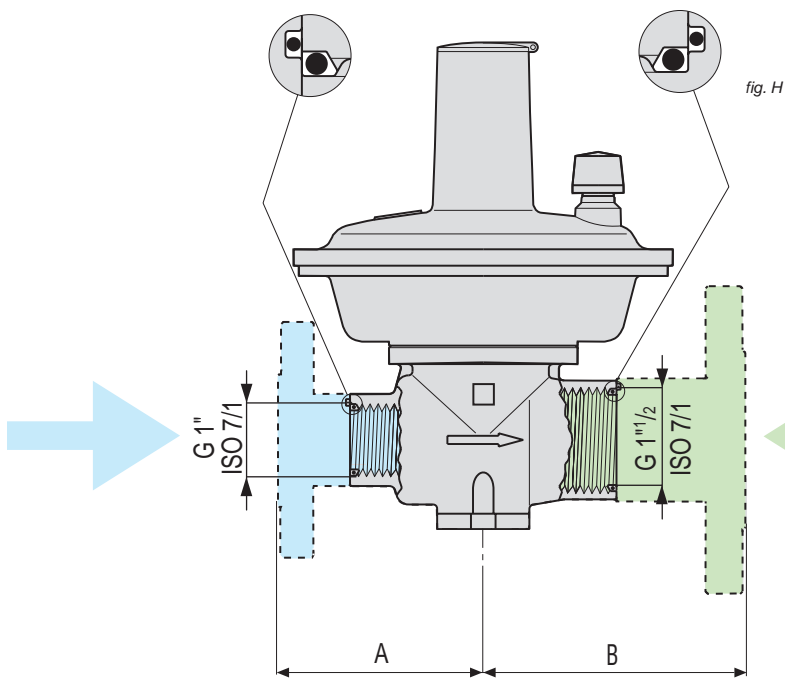

**ESEMPI DI INSTALLAZIONE  
APPLICATION AVAILABLE**

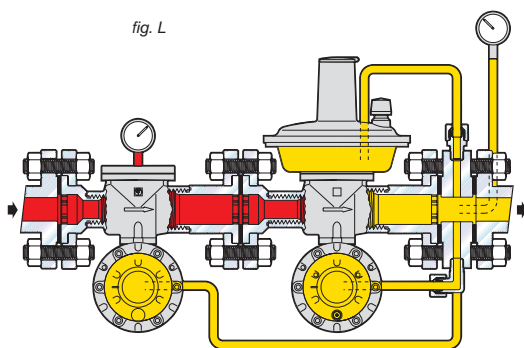
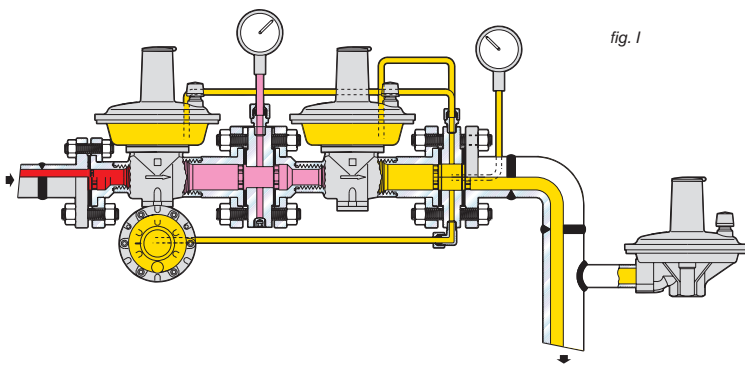

## USCITA - OUTLET

fig. 1  
**071.10062.01**

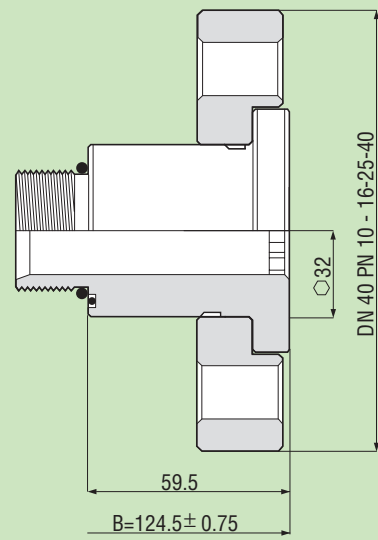

FLANGIE IN ALLUMINIO  
ALLUMINIUM FLANGES  
EN 1092 - 4  
DN 40 PN 10 - 16 - 25 - 40  
DN 1 1/2 matches ASME 150

fig. 2  
**071.00320.00**

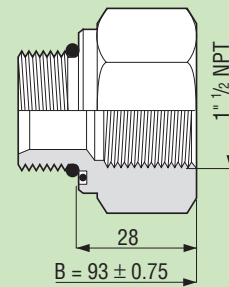
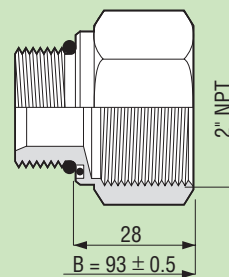

fig. 3  
**071.00390.00**





## TABELLA DI CODIFICA T-00211 Mod. DIVAL 507-512 - 520-522

LEGENDA	
① ②	Sigla prodotto
③	Modello Regolatore
④	Accessori
⑤	Targhettatura
⑥	Connessioni entrata/uscita
⑦	Pressione d'ingresso MIN
⑧	Pressione d'ingresso MAX
⑨ ⑩	Tarature
⑪	Versione
STD	Standard
G.N.	Gas Naturale
G.P.L.	Gas Petrolio Liquefatto
BP	Bassa Pressione
MP	Media Pressione
TR	Testata Ridotta (Alta Pressione)
AP	Alta Pressione

MODELLO G.N. / G.P.L.	
A	DIVAL 507 BP
B	DIVAL 507 MP
C	DIVAL 507 TR
G	DIVAL 512 BP
H	DIVAL 512 MP
I	DIVAL 512 TR
1	DIVAL 520 BP 1 TESTATA
2	DIVAL 522 BP 2 TESTATE
3	DIVAL 520 MP 1 TESTATA
4	DIVAL 522 MP 2 TESTATE
5	DIVAL 520 TR 1 TESTATA
6	DIVAL 522 TR 2 TESTATE

targhettatura			
LINGUA	LOGO	U.M.	
A	ITALIANO / INGLESE	PERSONALIZZATO CLIENTE	MBAR
B	•		MBAR
C	ITALIANO / INGLESE	PIETRO FIORENTINI	MBAR
D	•		
E	•		
F	ITALIANO / INGLESE	PIETRO FIORENTINI	KPA
G	ITALIANO / INGLESE	PIETRO FIORENTINI	mmH2o
H	INGLESE	PIETRO FIORENTINI	IMPERIALI
K	INGLESE	PIETRO FIORENTINI USA	IMPERIALI

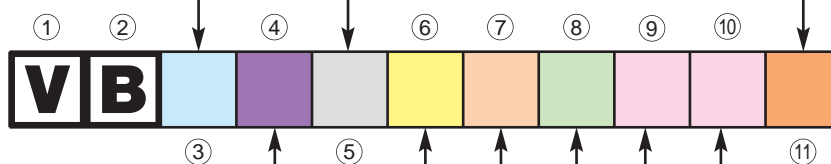

	CORPO	BLOCCO	SFIORO
A	GHISA	SI	SI
B	GHISA	SI	NO
C	GHISA	SI	BLOCCATO
D	GHISA	NO	SI
E	GHISA	NO	NO
F	GHISA	NO	BLOCCATO

Con distanziale (riattivabile)

Con 3 OR (non riattivabile)

CONNESSIONI	DIVAL 507		DIVAL 512		DIVAL 520-522	
	DnE (1")	DnU (1")	DnE (1")	DnU (1"1/2)	DnE	DnU
0 Corpo Rp ISO 7/1	Corpo	Corpo	Corpo	Corpo		
1 .						
2 .						
3 DnE/U 25 PN40 -ASME-(202)	071.10063.01	071.10063.01	-----	-----		
4 DnE/U 25 PN40 -ASME-(223)	070.10066.01	070.10066.01	-----	-----		
5 DnE 25 x DnU 40 PN40 (ASME)	-----	-----	070.10065.01	071.10062.01		
6 Dne/U 40 PN40 (ASME)	-----	-----	070.10067.01	071.10062.01		
7 .						
8 .						
9 Raccordi NPT	070.00210.00	070.00210.00	070.00210.00	071.00320.00		
A 1" NPT x 2" NPT	070.00210.00	071.00310.00	070.00210.00	071.00390.00		
B 1"1/2NPT x 1"1/2NPT	071.00300.00	071.00300.00	071.00300.00	071.00320.00		
C DNE/U 1" ANSI 300	070.10034.01	070.10034.01				
D 3/4" NPT x 1" NPT	071.00640.00	070.00210.00				
U DnE/U DN 50 PN 40					Corpo	Corpo
V DnE/U 2" ASME 150					Corpo	Corpo
W G 2" ISO 7/1					Corpo	Corpo
X 2" NPT					Corpo	Corpo

Questa tabella è a titolo dimostrativo.  
Vi preghiamo di riferirVi al Configuratore Minireg per le possibili versioni e configurazioni disponibili su sito web:  
[www.fioxchange.com/Servizi Fiorentini](http://www.fioxchange.com/Servizi Fiorentini)

*This table is only demonstration.  
To create all allowable versions please refer to FM configurator on website:  
[www.fioxchange.com/Servizi Fiorentini](http://www.fioxchange.com/Servizi Fiorentini)  
where you can also find english translation*





VERSIONE	
A	STANDARD X G.N. / G.P.L.
B	•
C	X FLUIDO OSSIGENO
D	STD + CON PIOMBATURA
E	STD + TIPO IT.
F	•
G	STD + TAPPO CHIUSURA REG. INVIO LABILE (DODECAGONALE)
H	STD + GUARNIZIONI IN VITON
I	STD + ESECUZIONE MONITOR (PRESA IMPULSO INTERNA BLOCCATA)
J	•
K	•
L	•
M	STD + ETICHETTA OMOLOGATIVA TSE 11390
N	C + ETICHETTA TSE 11390
P	x FLUIDO AZOTO
Q	•
R	x BIOGAS
S	•
T	•
U	•
V	x FLUIDO ARIA
W	•
\$	VERSIONE PERSONALIZZATA CLIENTE

PER IL BLOCCO VEDI T-00210 (PAG. 16)

+

	Pu min (bar)	Pu max (bar)
B	0.2	2.9
C	0.3	4.3
D	0.4	5.8
E	0.5	7.2
F	0.6	8.7
G	0.7	10.1
H	0.8	11.6
I	0.9	13.0
J	1	14.5
K	1.5	21.7
L	2	29
1	2.5	36.2
M	3	43.5
2	3.5	50.8
N	4	60.0
3	4.5	65.3
P	5	72.5
Q	6	87.0
R	7	101.5
S	8	145.0
T	10	145.0
U	12	174.0
V	14	203.0
W	16	232.1
X	18	262.1
Y	19	275.6
Z	20	290.1

**Per l'ordinazione, seguire scrupolosamente quanto richiesto dalla casella 3 alla 11.**

- 1-2 Sigla identificativa del prodotto
- 3 Modello di regolatore
- 4 Accessori (dispositivi di sicurezza)
- 5 Targhettatura e imballo (x l'imballo multiplo con ordinativo minimo 10 pezzi e/o multipli di 10)
- 6 Raccorderia (da scegliere da tabella T-00211) pag. 8-9-10-11
- 7-8 Pressioni di ingresso MIN/MAX (N.B.: si deve inserire sempre prima quella minima)
- 9-10 Tarature pressione uscita nominali regolate e dispositivi di sicurezza standard
- 11 Versione

**N.B.:** Per eventuali versioni non previste dalla tabella, si prega di inviare una richiesta scritta descrivendo dettagliatamente le caratteristiche del prodotto.  
La Fiorentini Minireg S.p.A. si impegna a verificare la fattibilità di quanto richiesto.

		TARATURE (mbar)			
		STD		consigliate	
		Pd	Sf	Pdso	Pdsu
A	A	SENZA MOLLE			
A	E	15	32	43	6
A	J	18	32	43	10
A	M	19	32	43	10
A	Q	19	NO	32	10
A	Y	20	32	43	10
B	P	20	NO	32	10
B	W	21	32	43	10
C	A	21	NO	32	10
D	I	22	32	43	10
C	Q	22	45	70	10
C	Y	25	35	45	10
D	G	20	40	50	10
D	D	28	38	48	10
D	L	30	60	70	22
D	P	30	40	50	15
D	X	35	60	70	22
E	I	40	60	80	20
E	N	45	75	90	30
E	U	50	70	90	30
F	G	50	75	110	30
F	P	55	75	125	20
F	T	60	90	120	30
F	U	65	95	125	20
G	A	70	100	130	40
G	I	80	120	150	40
G	L	100	130	150	10
G	Q	100	140	160	50
G	Z	110	170	200	70
G	Y	120	160	200	80
H	G	150	200	250	70
H	P	160	200	250	120
H	R	200	270	365	100
H	T	210	280	350	150
H	W	240	300	360	150
H	S	250	300	365	100
I	A	300	360	440	180
I	G	300	600	750	150
I	E	300	NO	360	240
I	I	350	450	520	250
K	L	392	520	588	245
K	E	400	500	550	NO
I	L	400	650	950	200
I	K	450	700	1000	250
I	M	500	750	900	250
I	P	580	700	850	300
I	Q	600	750	1000	200
I	U	700	850	1100	400
K	F	700	900	1000	NO
I	W	800	1200	1500	400
I	Y	900	1150	1600	600
J	A	1000	NO	1400	600
J	B	1000	1200	1800	500
J	C	1000	1250	1450	350
J	E	1000	1800	2500	500
J	D	1100	1400	1700	400
L	H	1200	1500	1800	NO
J	F	1200	1600	2000	400
L	V	1400	2000	2500	1000
J	H	1500	NO	2000	1000
J	G	1500	1800	2500	1000
J	K	1500	2000	3000	200
J	M	1500	2500	3000	700
K	G	1700	2300	3000	200
J	N	1750	2500	3200	1000
J	Q	1750	NO	2500	1000
J	L	1800	2500	3400	1000
J	T	1900	2500	3600	1000
J	R	2000	NO	2400	1600
J	P	2000	2500	3400	1000
K	H	2000	2600	3000	200
K	U	2400	3000	3400	1000
J	S	2500	NO	3000	1000
K	V	3000	3700	4000	2000



## DIMENSIONE DEGLI IMBALLI - PACKAGING DIMENSIONS

RIFERIMENTO REFERENCE	PEZZI PIECES Nr.	DIMENSIONI DIMENSIONS cm	VOLUME VOLUME m <sup>3</sup>	PESO WEIGHT Kg	PALLET MAX LxPxH cm		
					PEZZI PIECES Nr.	PESO WEIGHT Kg	VOLUME VOLUME m <sup>3</sup>
DIVAL 507 - 512	1	20x20x25	0.010	3.3÷3.9	120x80x150		
					120	396-468	1.44
DIVAL 507 - 512 +LA	1	40x20x22.5	0.018	4.1÷4.7	120x80x150		
					60	296-282	1.44
DIVAL 520 - 522	1	38x38x27	0.038	15.2÷16.8	120x80x165		
					30	456-504	1.58
DIVAL 520 - 522 +LA	1	38x38x27	0.038	16.0÷17.6	120x80x165		
					30	480-528	1.58

Il presente stampato è finalizzato a fornire utili elementi informativi al progettista e/o all'installatore.

È necessario precisare che le fotografie e le notizie contenute nel presente catalogo, sono da ritenersi informazioni di carattere generale. Il nostro SERVIZIO TECNICO è a disposizione per eventuali ulteriori informazioni necessarie per l'esatta definizione delle caratteristiche del prodotto.

In considerazione alla normale evoluzione del prodotto, la FIORENTINI MINIREG S.p.A. si riserva la facoltà di apportare in qualsiasi momento modifiche ai dati concernenti gli articoli illustrati.

*The aim of this document is to provide useful information to the designer and/or installer.*

*Upon consideration of the normal product evolution, FIORENTINI MINIREG S.p.A. is at any time free to modify data concerning the items presented.*

*It is necessary to state that the photographs and the news concerning this catalogue are to be considered as general information only.*

*Our TECHNICAL ASSISTANCE is available for further information concerning the exact definition of the product characteristics.*

*Fiorentini Minireg reserves the right to make changes to this information without notification with the view of continuous improvement.*

### LEGENDA:

<b>Ps</b>	= Pressione di progetto
<b>Pu</b>	= Pressione in entrata
<b>Pu max</b>	= Massima pressione in entrata
<b>Pd</b>	= Pressione in uscita
<b>Pd max</b>	= Massima taratura ammessa
<b>Wd</b>	= Campo di regolazione
<b>Wdo</b>	= Campo di regolazione blocco di max
<b>Wdu</b>	= Campo di regolazione blocco di min.
<b>Bpu</b>	= Campo di pressione in entrata
<b>Pds</b>	= Set point
<b>AC/AG</b>	= Grado di precisione
<b>SG</b>	= Classe di pressione chiusura
<b>Q</b>	= Portata nominale
<b>C<sub>1</sub></b>	= Coefficiente di forza
<b>Cg</b>	= Coefficiente di portata

### LEGEND:

<b>Ps</b>	= Max allowable pressure
<b>Pu</b>	= Inlet pressure
<b>Pu max</b>	= Max inlet pressure
<b>Pd</b>	= Outlet pressure
<b>Pd max</b>	= Permissible outlet pressure
<b>Wd</b>	= Set range
<b>Wdo</b>	= Opso set range
<b>Wdu</b>	= Upso set range
<b>Bpu</b>	= Inlet pressure range
<b>Pds</b>	= Set point
<b>AC/AG</b>	= Accuracy class
<b>SG</b>	= Lock up pressure class
<b>Q</b>	= Volumetric flowrate
<b>C<sub>1</sub></b>	= Body shape factor
<b>Cg</b>	= Flow rate coefficient

# Mod. LA CE

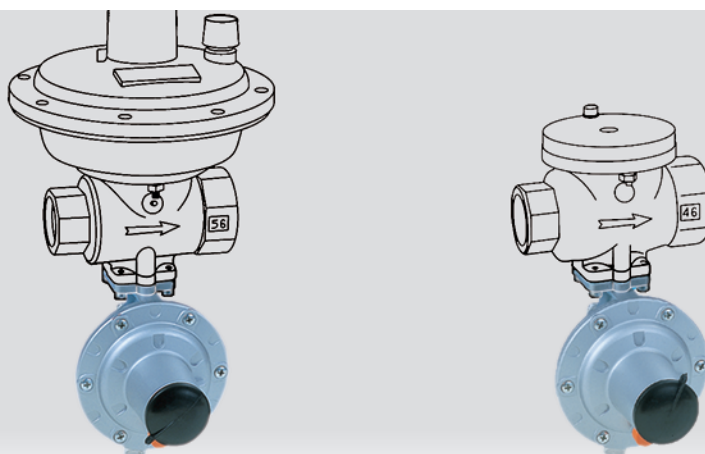

## INTRODUZIONE

La valvola pressostatica o di blocco mod. LA è un dispositivo di sicurezza che può essere applicato agli apparecchi di regolazione quali ad esempio tutti i regolatori della serie DIVAL ed agli apparecchi di intercettazione quali le valvole DILOCK.

Le valvole pressostatiche hanno il compito di interrompere il flusso del gas, per mezzo di un otturatore esterno, ogni qualvolta si crea una condizione di pericolo; il loro intervento è condizionato al collegamento ad un punto di monitoraggio della canalizzazione, generalmente a valle dell'apparecchio di regolazione o intercettazione.

## INTRODUCTION

The mod. LA shut-off valve or pressure switch valve is a safety device which may be applied to the regulation equipment to all DIVAL series regulators and to DILOCK shut-off valves.

The purpose of the shut-off valves is to interrupt the gas flow, through an external plug, each time a dangerous situation occurs.

Their operation is sensed at a point downstream of the regulator or shut-off device.

They are suitable for Natural gas, LPG and other non corrosive gases.

## CARATTERISTICHE PRINCIPALI

- Classe di temperatura: 2 (-20°C + 60°C).
- Massima pressione ammessa sul sistema di otturazione esterno: PS 20 bar.
- Otturatore con By-pass per facilitare il riarmo con pressioni di alimentazioni elevate.
- Ripristino esclusivamente manuale (salvo intervento per eccesso di temperatura).
- Tappo con possibilità di fissaggio del sigillo verifica effrazione.
- Presa di pressione con filettatura da 1/4 F ISO 7/1 con filtro.
- Collegamento remoto dello sfiato del coperchio dell'organo di misura con filettatura 1/8 F ISO 228.
- Pulsante di test per prova d'intervento - standard per DIVAL 160 e 250, 520 e 522.
- Predisposizione per contatto elettrico segnalazione d'intervento per sistemi di tele sorveglianza (a richiesta).

Il dispositivo interviene nei seguenti casi:

- AUMENTO DI PRESSIONE - nel caso in cui la pressione monitorata aumenti oltre i limiti di taratura. (la taratura è variabile dall'esterno secondo il campo previsto dalla molla utilizzata).
- DIMINUZIONE DI PRESSIONE - nel caso in cui la pressione monitorata diminuisce oltre i limiti di taratura (la taratura è variabile dall'esterno secondo il campo previsto dalla molla utilizzata).
- AUMENTO DELLA TEMPERATURA - nel caso in cui la temperatura della valvola aumenti oltre i 170/190°C.

CONFORME ALLE DIRETTIVE 97/23 CE PED

## MAIN FEATURES

- Temperature class: 2 (-20°C + 60°C); (-68°F +140°F).
- Maximum pressure: Ps 20 bar - Ps 290 Psi.
- Easy resetting with high inlet pressures.
- Manual reset only (except for the intervention in case of Temperature increase).
- Security tab is included on the cap to enable checking the seal for any violation.
- Inlet pressure to the valve is measured upstream.
- "Test" button is standard for DIVAL models 160 and 250, 520 and 522.
- An electric contact signal can be fitted to confirm the state of operation (upon request).

The device operates in the following cases:

- OVER PRESSURE - in case the monitoring pressure exceeds the calibration limits. (the calibration changes from the outside according to the range forecast by the spring in use).
- UNDER PRESSURE - in case the monitoring pressure goes below the calibration limits (the calibration changes from the outside according to the range forecast by the spring in use).
- TEMPERATURE INCREASE - in case the valve temperature goes further 170/190°C - 338/374°F.

CONFORMING TO THE 97/23 CE PED DIRECTIVE





## TABELLA DI CODIFICA T-00210 Mod. LA

LEGENDA	
① ②	Sigla prodotto
③	Modello
④	Tipo di intervento
⑤	Targhettatura
⑥ ⑦	Tarature
⑧ ⑨	Versione
STD	Standard
G.N.	Gas Naturale
G.P.L.	Gas Petrolio Liquefatto
BP	Bassa Pressione
MP	Media Pressione
TR	Testata Ridotta (Alta Pressione)

MODELLO G.N. / G.P.L.	
A	x DIVAL 507
B	x DIVAL 512
C	•
D	•
* E	x DIVAL 160
* F	x DIVAL 250
G	x CP - L
* H	x DIVAL 520 - 522

TIPO G.N. / G.P.L.		INTERVENTO
A	BP	MAX
B	BP	MAX/MIN
C	MP	MAX
D	MP	MAX/MIN
E	TR	MAX
F	TR	MAX/MIN

TARGHETTATURA	
A	ITALIANO / INGLESE
B	FRANCESE / SPAGNOLO
C	TEDESCO / GRECO

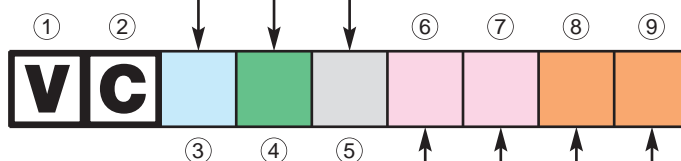

TARATURE (mbar) BP			
		Pdsu	Pdsu
		Max./Min.	Solo Max
A	A	SENZA MOLLE	
A	L	30	8
A	Q	32	10
A	E	43	6
A	Y	43	10
C	Y	45	10
D	D	48	10
D	G	50	10
D	P	50	15
D	S	60	10
E	Q	70	10
D	L	70	22
E	C	75	30
E	I	80	20
E	J	80	30
E	U	90	30
E	V	100	10
E	W	100	50
F	G	110	30
F	T	120	30
F	R	120	10
F	I	120	40
F	Q	125	10
F	P	125	20
G	A	130	40
G	B	140	30
G	C	140	50
G	D	150	10
G	G	150	20
G	I	150	40
G	Q	160	50
G	U	160	60
H	A	170	70
H	B	180	60

TARATURE (mbar) MP			
		Pdsu	Pdsu
		Max./Min.	Solo Max.
G	B	140	30
G	C	140	50
G	D	150	10
G	G	150	20
G	I	150	40
G	Q	160	50
G	U	160	60
H	A	170	70
H	B	180	60
H	E	190	80
G	V	200	65
G	Z	200	70
G	Y	200	80
G	X	200	100
H	U	210	90
H	V	230	60
G	S	250	10
H	F	250	60
H	G	250	70
H	P	250	120
H	J	300	60
H	Q	300	120
H	R	300	120
H	T	350	150
H	W	360	150
I	E	360	240
H	S	365	100
I	B	400	60
H	Y	400	200
H	X	440	110
I	A	440	180

TARATURE (mbar) TR			
		Pdsu	Pdsu
		Max./Min.	Solo Max
I	A	440	180
K	Z	480	340
I	C	500	100
I	I	520	250
I	J	600	200
I	F	750	100
I	G	750	150
I	H	800	200
I	P	850	300
I	M	900	250
I	L	950	200
I	N	1000	100
I	Q	1000	200
I	K	1000	250
I	U	1100	400
I	V	1200	500
I	T	1200	300
I	R	1300	300
I	S	1400	250
J	A	1400	600
J	C	1450	350
I	W	1500	400
I	X	1500	500
I	Y	1600	600
J	D	1700	500
K	M	1750	600
J	B	1800	500
J	J	2000	100
J	F	2000	400
K	T	2000	500
K	W	2000	700
J	H	2000	1000
J	R	2400	1600
J	E	2500	500
J	G	2500	1000
J	U	3000	100
J	K	3000	200
J	M	3000	700
J	L	3000	1000
J	S	3000	1500
J	N	3200	1000
J	P	3400	1000
J	T	3600	1000
J	W	4000	1000
J	X	4000	2000
J	Y	4500	100
J	Z	5000	300
K	A	5000	2500
K	D	5400	3000

VERSIONE	
0 0	X FLUIDO G.N.
0 1	•
0 2	•
0 3	•
0 4	X FLUIDO OSSIGENO
0 5	•
0 6	00 + GUARNIZIONI IN VITON
0 7	•
0 8	00 + APPLICAZIONE MICRO
0 9	•
1 0	•
1 1	•
1 2	•
1 3	X FLUIDO AZOTO
1 4	•
1 5	•
1 6	X FLUIDO ARIA
1 7	X BIOGAS
1 8	•
1 9	•
2 0	•
2 1	00 + VITON + MICRO

\* = Pulsante test standard  
Standard test bottom

Questa tabella è a titolo dimostrativo.  
Vi preghiamo di riferirVi al Configuratore Minireg  
per le possibili versioni e configurazioni  
disponibili su sito web:  
[www.fioxchange.com/Servizi Fiorentini](http://www.fioxchange.com/Servizi Fiorentini)

*This table is only demonstration.  
To create all allowable versions please  
refer to FM configurator on website:  
[www.fioxchange.com/Servizi Fiorentini](http://www.fioxchange.com/Servizi Fiorentini)  
where you can also find english translation*





